



nexa3D[®]

Design Guide for 3D Printed Tooling

Contents

Maximizing Printability	3
Split Molds	6
Maximizing Moldability	8
Accelerating Print	11
MIM & CIM Quick guide	12

Maximizing Printability

1. Adjust part shrinkage

Part shrinkage is the dimensional change that occurs in a molded part as it cools off after injection. Shrinkage can vary a lot, and is mainly dependent on material type and temperature during injection.

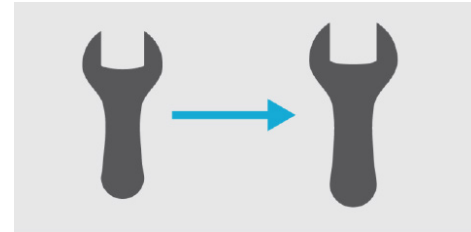

2. Subtract part from mold

Almost all 3D CAD systems have multiple tools that can assist users throughout the mold design process. These tools can be used to subtract the part from the mold insert.



3. Check build orientation

Orientation of a part must reduce the presence of overhangs as much as possible Z height print sequence on the Z-axis.

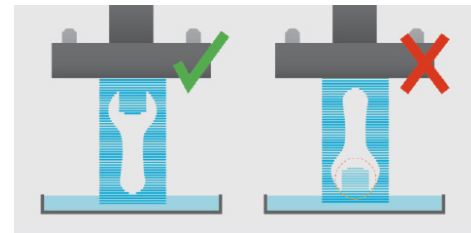

4. Select mold & frame size

Choose the optimal mold size, based on part size and matching standard mold frame. The wall thickness between the cavity and outer surface should be at least 5mm.

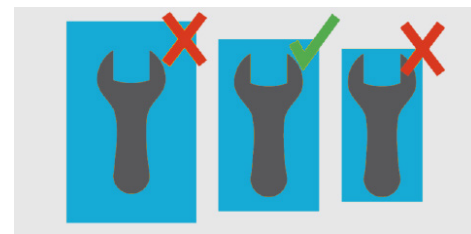

5. Place inlet

Inlet runner placement must secure that the feedstock material reaches all areas of the mold before hardening. The deepest cross section is ideal to provide the best flow and minimize voids and sinking.

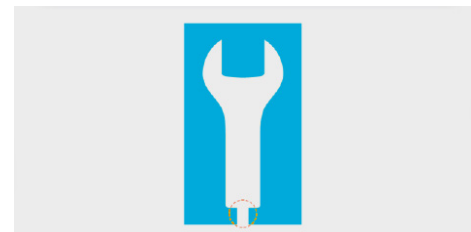

6. Place outlets

Outlet runners should preferably be placed opposite of the inlet, and at or close to points at the end of fill. The outlets also capture any potential cold slug and make it possible for the operator to check if the mold has been properly filled.

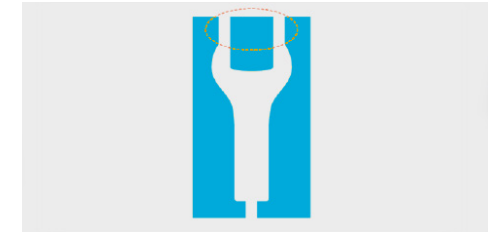

7. Check flow

Main considerations that influence the flow in a mold are material flow rate, part volume, part design, material type and grade, and processing conditions.

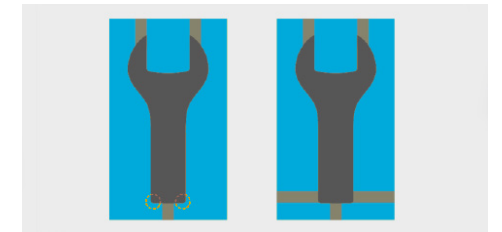

8. Place gates

Place gates where the runners connect to the part. Gates are a narrowing of the runners, which diminish the size of injection marks on the part surface, and which can help guide the feedstock material into the part cavity at the right angle and pressure.

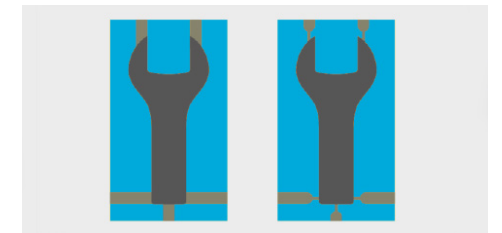

9. Place inlet ring

The inlet ring is a raised lip around the mold inlet. Which enables a secure seal between the mold inlet and the injection point.

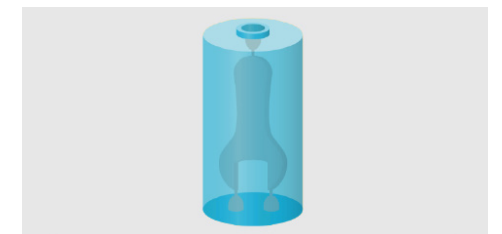

10. Save mold as STL

After designing the mold insert, it must be saved in the STL file format. The 3D printer software is then able to slice the model and create the program for the 3D printer.

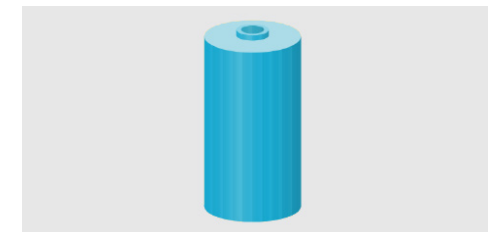

Maximizing Printability

Supported wall thickness

A supported wall is one that is connected to other walls on two or more sides. A supported wall smaller than 1mm is not recommended.

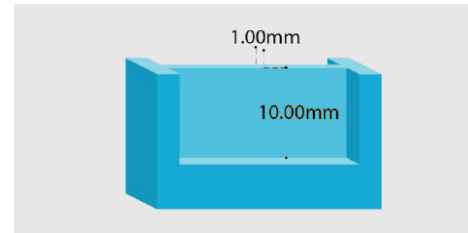

Unsupported wall thickness

An unsupported wall is one that is connected to other walls on fewer than two sides. An unsupported wall that is thinner than 0.8mm may warp or detach.

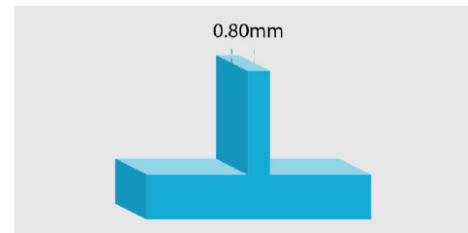

Unsupported overhang

An overhang refers to a part of the model that sticks out parallel to the build platform. Horizontal overhangs will be slightly deformed beyond 2.5mm and become increasingly deformed as the length of the overhang increases.

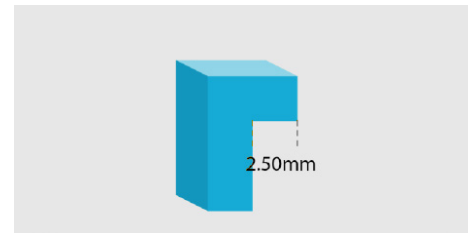

Horizontal support span

A span is the distance between two intermediate supports of structure. While printing horizontal spans is discouraged, certain geometries print well. For a 5mm wide and 3mm thick beam, spans beyond 5mm are likely to fail. Wider beams must be kept shorter to avoid breaking during the peeling process.

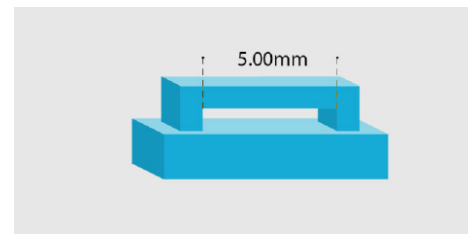

Vertical wire diameter

A wire is a feature whose length is greater than two times its width. The ration is key to printing wires at 0.5mm thickness you can print up to 7mm tall before you begin to see waving, 1mm wires can get up to 30mm tall without defects.

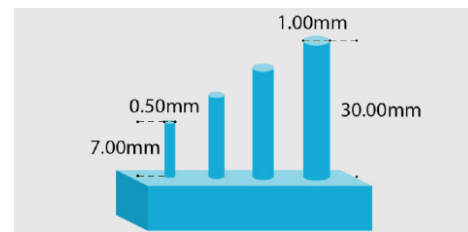

Embossed detail

Embossed details are shallow raised features on your model, such as text. Details smaller than 0.02mm in thickness and height may not be viable on your print.

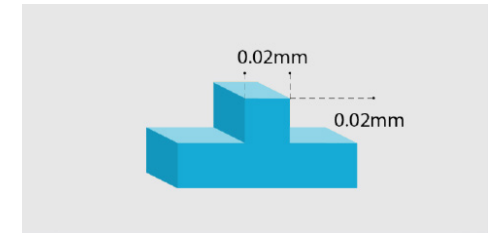

Engraved detail

Engraved details are imprinted and recessed features on your model. Details recessed less than 0.02mm in thickness and height may not be visible because they will be fused with the rest of the model during the print process.

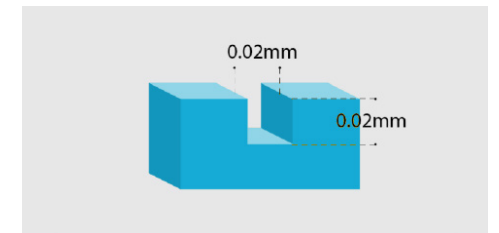

Clearance between molds

Clearance is the amount of distance between molds. A clearance of less than 2mm may cause parts to fuse.

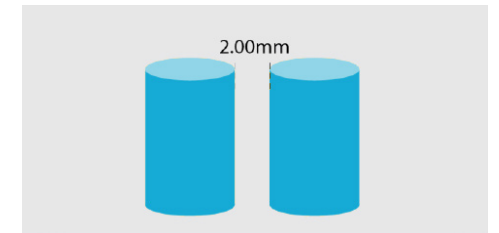

Hole diameter

Straight holes with a diameter of less than 0.7mm in the x, y and z axis may close off during printing. If the hole is a curved canal the diameter should be 1mm or more to avoid such issues

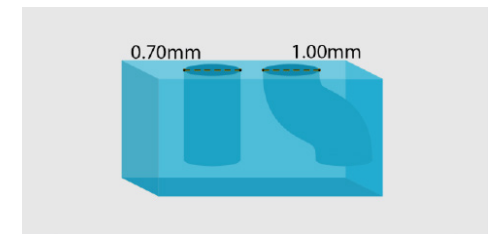

Maximizing Printability

Orientation

When orienting the part in the printer, it is necessary to keep in mind that each individual layer is very thin. This is related to the concepts of overhangs and bridging. In this section, simple ways are shown which allow the printing of a hexagonal part.

Rotation

A simple rotation of the part, can prevent large overhangs.

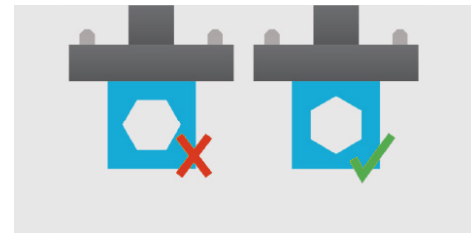

Splitting the mold

Splitting the mold in two allows production of the part without printing a large overhang. Splitting the mold is only used to increase printability. Demolding will still be done through dissolving the mold resin, thus demolding considerations associated with conventional split molds, can be disregarded.



Support inside part

If the part cannot be rotated or split, it may also be a solution to print pillars of support material which can be removed manually.

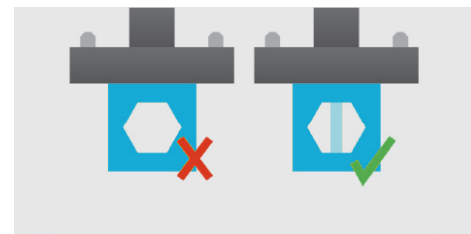

Vacuum relief tracks

If a mold design involves a large enclosed cavity, it may act as a suction cup on the flexible foil in the printer vat during printing, deforming the foil with each added layer. This will increase the foil wear and may even lead to delamination of the part. Expanding outlet exits hole with a track is a good way to mitigate this.

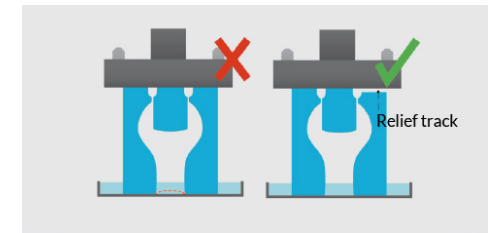

What is an overhang

A 3D printing overhang is any part of a print that extends outward, beyond the previous layer, without any direct support. As any layer in a 45 degree overhang is 50% supported by the layer beneath. Overhangs up to 45 degrees, and sometimes even more, can be printed without loss of quality. The potential side effects of tilting a print include altering the surface roughness and part tolerances.

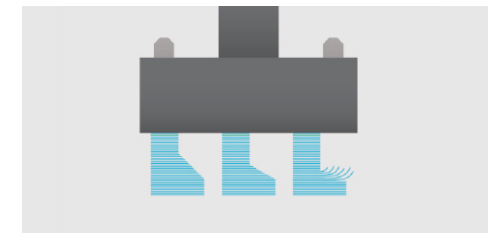

Chamfer edges towards buildplane

Adding a chamfer on the edges towards the buildplane makes it easier to remove the printed mold from the buildplane. Place a spatula in the groove created between the chamfered edge and the buildplane to separate the mold from the buildplane.

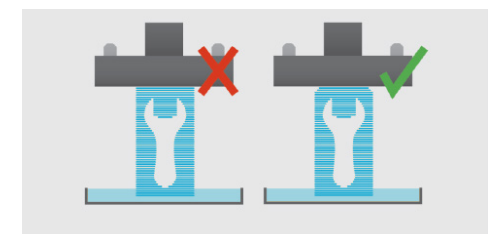

Split Molds

Split molds and mold assemblies

Splitting molds into two or more pieces and assembling them with nuts and bolts has several advantages.

- It allows the designer to take advantage of the fact that the last layer printed is always has a mirror finish.
- It potentially solves problems with bridging or overhang during printing.
- Cleaning of molds after printing becomes easier as leftover resin has fewer places to be trapped.
- Inspection of molds for printing flaws such as closed vents or lost features becomes easier.
- The strength of mold features increases as they are all available for the UV post curing process.
- The parting line can act as venting, just as in conventional injection molding.
- Inspection of the molded result becomes easier and faster.
- Some designs may even allow for a full manual demolding directly after molding, skipping the dissolving step entirely.

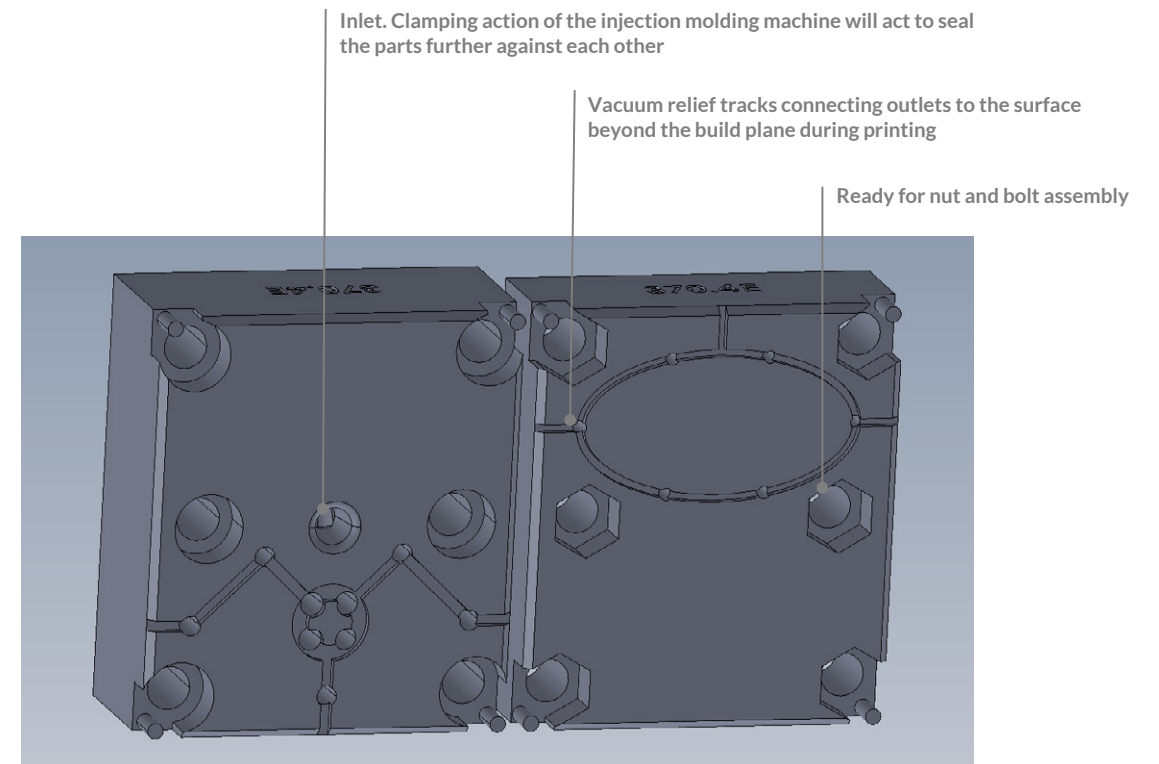
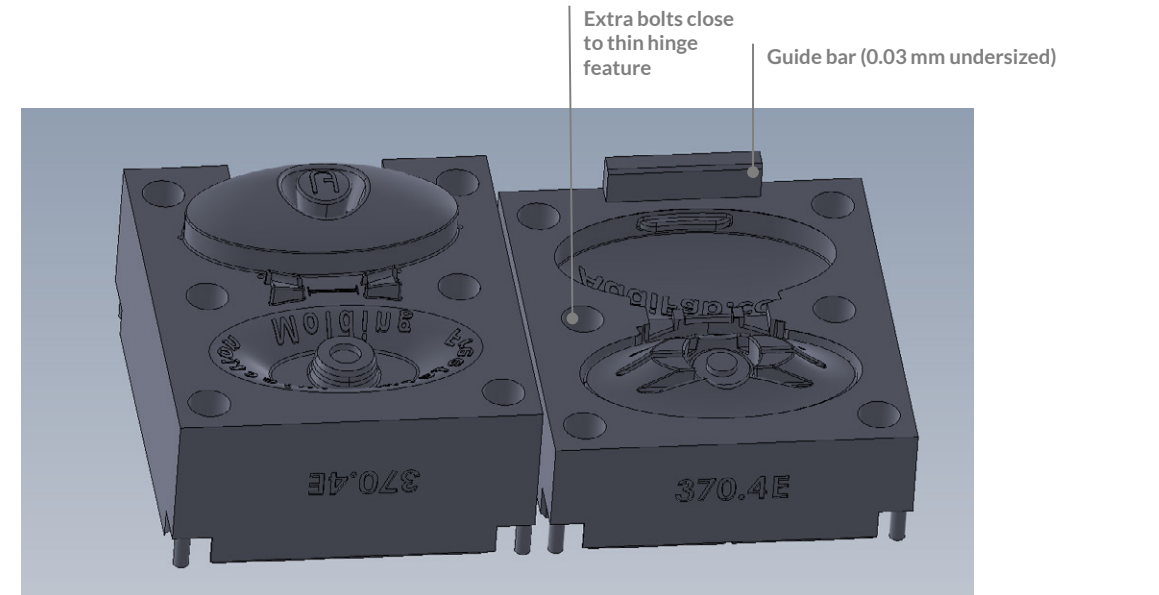
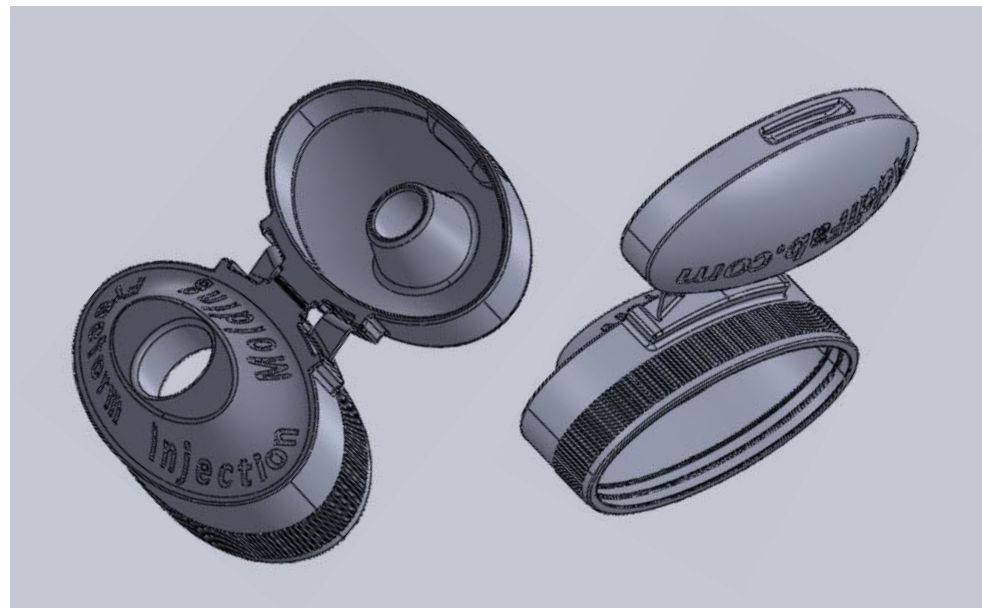

Split Molds

Split molds

The Nexa3D printing resins are dissolvable, thus designing for demolding is not necessary. In cases where fast results are desired, you may choose to use manual demolding, as demolding through dissolving takes 24–72 hours. The printed molds differ from metal molds, as their surface is not smooth, but lightly rippled from the layer fusing. Therefore, manual release of a component from printed molds can be harder.

Grooves around split lines

Add grooves in split lines to ease separation. The groove makes it easier to place a spatula or similar separation tool in between the two mold sections.

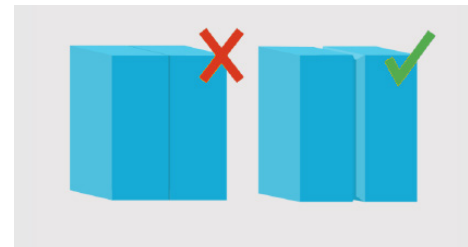

Limiting dissolving

In cases where aspects of the component design may only be freed from the mold through dissolving, or certain areas are too fragile for manual demolding, a mixed method may be applied. The mold then must be designed so that sections of the mold can be manually removed. The less resin to dissolve, the quicker the dissolving.

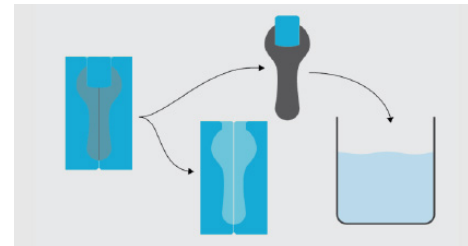

Manual demolding

Complete manual demolding can sometimes be successful with softer plastics, provided the mold design allows for this. For feedstock materials which tolerate 80°C, part of the mold may be removed, followed by a heating of the part and remaining mold sections. This will make the mold more pliable and ease full manual demolding.

Drafts and angles

In a conventional mold drafts are used to ease demolding. In printed molds this does not always apply. As the angle of the draft is built up by layers, the drafts have staircasing, which depending on placement and angle can result in barbs making the demolding more difficult.

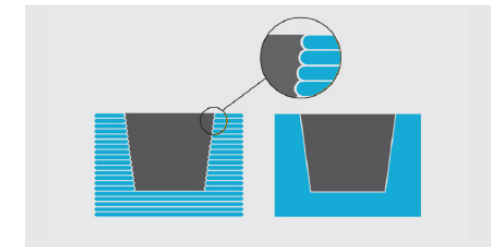

Using slip

Using slip in printed resin molds can be helpful to release the component in some cases. However, some slip solutions may react with the resin or compromise the tolerances of the injected component. The slip can also get trapped like air, in small pockets, causing unfilled parts.

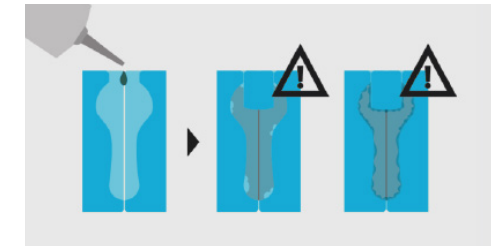

Testing your options

Splitting printed molds can present some challenges as the rippled surface can cause material to get in the mold and overall increases the components adherence to the mold. Therefore it is a good idea to print and fill 4–8 test molds when making a new part, to safely determine the optimal demolding approach with regards to time, tolerances and quality.

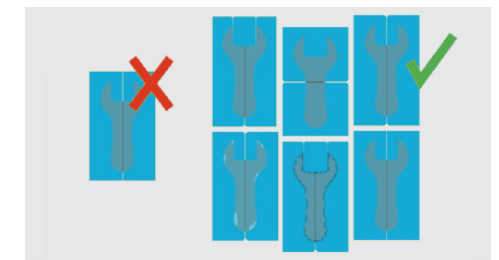

Maximizing Moldability

Debossed features

If a part contains a debossed feature such as a blind hole, the strength of the printed material should be taken into consideration. At most a printed core can be expected to hold if the length does not exceed the core diameter.

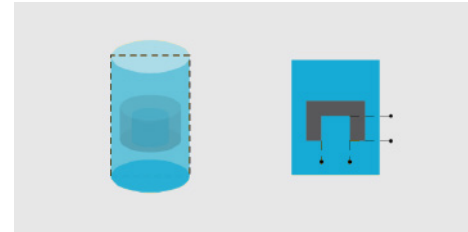

Thin walled hollow features

When injecting molding thin walled hollow features, best results are achieved with steel cores. Printed cores are applicable when they are well supported and have enough bulk to withstand the thermal impact of the injection molding process.

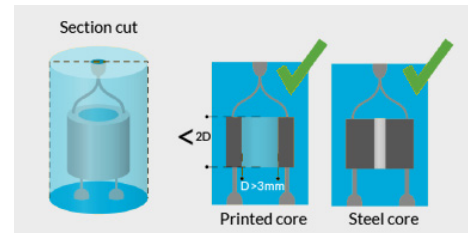

Minimizing core displacement

When applying printed cores, the flow of the polymer melt should be carefully considered to prevent any dislocation of the core during the injection molding process. This is generally achieved by creating a uniform flow along the length of the core.

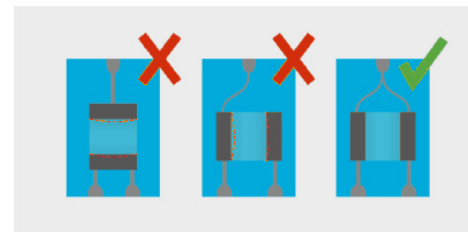

Supporting cores

Printed as well as steel cores must be supported in both ends, ideally reaching from end to end of the mold.

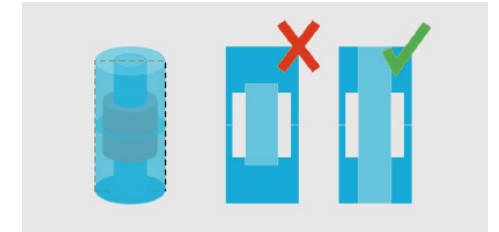

Multi mold assemblies

Some cores may have holes or other features which must be precisely located in a mold. If the core is printed separately, a lock and key design will aid the operator assembling the mold parts. Using a size difference of 0.03mm will give a tight fit

When designing a mold which consists of multiple splits and/or cores, it is advised to use lock and key design, to ensure precise assembly. This constitutes creating interfaces, which can only connect one way.

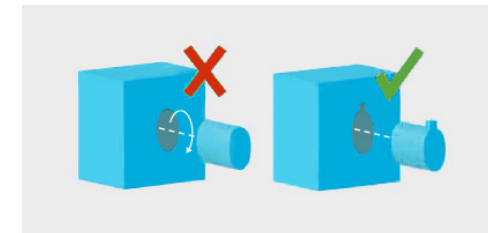

Multi mold: keeping it all together

Liberal application of 4.6mm pins and bolts will ensure that all mold parts stay where they should during injection molding. The most effective fixation agent however remains the closing pressure of the molding machine, so orienting the mold assembly to make best use of this is a good idea.

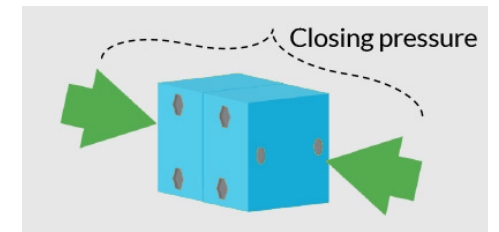

Maximizing Moldability

If in doubt, make an outlet

Filling a cavity during injection molding can be likened to blowing up a balloon. To make sure that it reaches all corners without leaving air gaps, an outlet may be needed. It may also not be needed but there is no harm in adding an extra outlet.

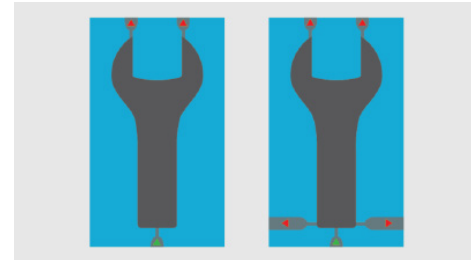

Printed mold sleeve

By reducing the wall thickness of the oriented mold and letting it follow the contours of the part, it is possible to reduce the demolding time and the resin consumption.

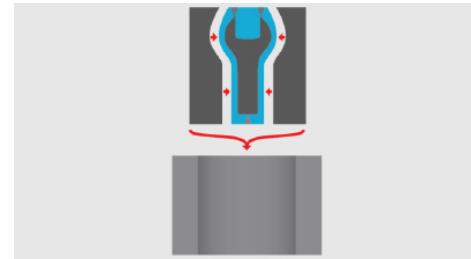

Outer wall thickness

While designing the mold, it is important to keep an eye on the wall thickness. The mold may rupture during injection molding if the walls are not strong enough. Generally speaking, the walls should be as thick as the cavity inside them.

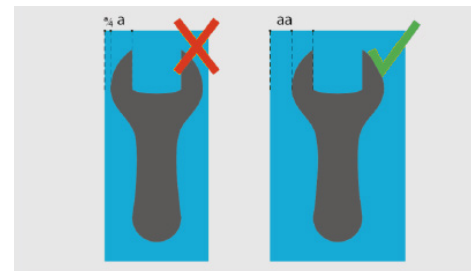

Mold fit

During injection molding, the printed mold is supported by the metal frame surrounding it. Design your mold with a 0.05mm gap. A larger gap will cause your mold to rupture during injection molding.

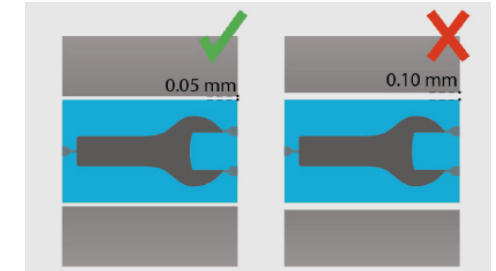

Cylindric molds are easiest

Your molds must be supported by a tightly fitting metal frame. Often, it will be possible to design the mold for both square and cylindrical frames. In this case, it is a good idea to choose a cylindrical mold, as it makes for a simpler fit.

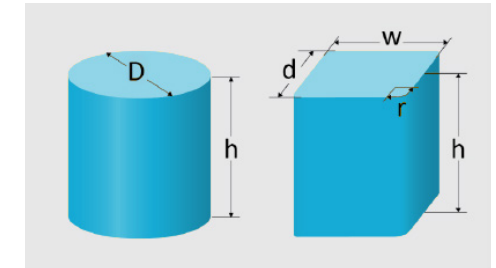

Weld lines

A weld line occurs where two melts fronts reach each other at a temperature where they do not merge completely. On the resulting part a crack or a weak line will be visible. Avoid this by moving the outlet or adding more inlet channels.

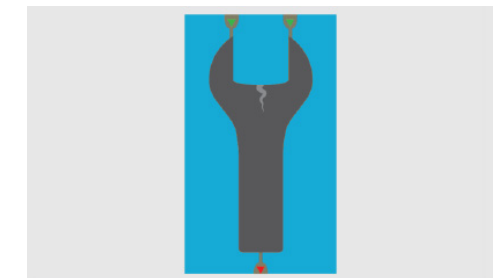

Maximizing Moldability

Air pockets

The air inside the printed mold must have vents to escape during the molding action. Lack of vents may cause the part to have rounded corners or lack edge features. Solve this by adding vents.

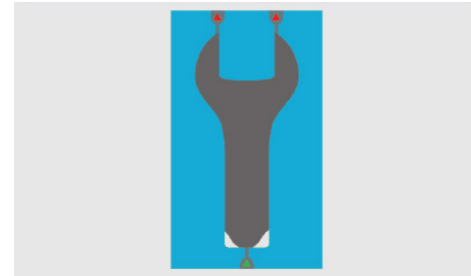

A fixture for milling

After injection molding, the part is fully encased and supported by the printed mold. This allows for easy machining or grinding to reach crucial surfaces finishes or dimensions.

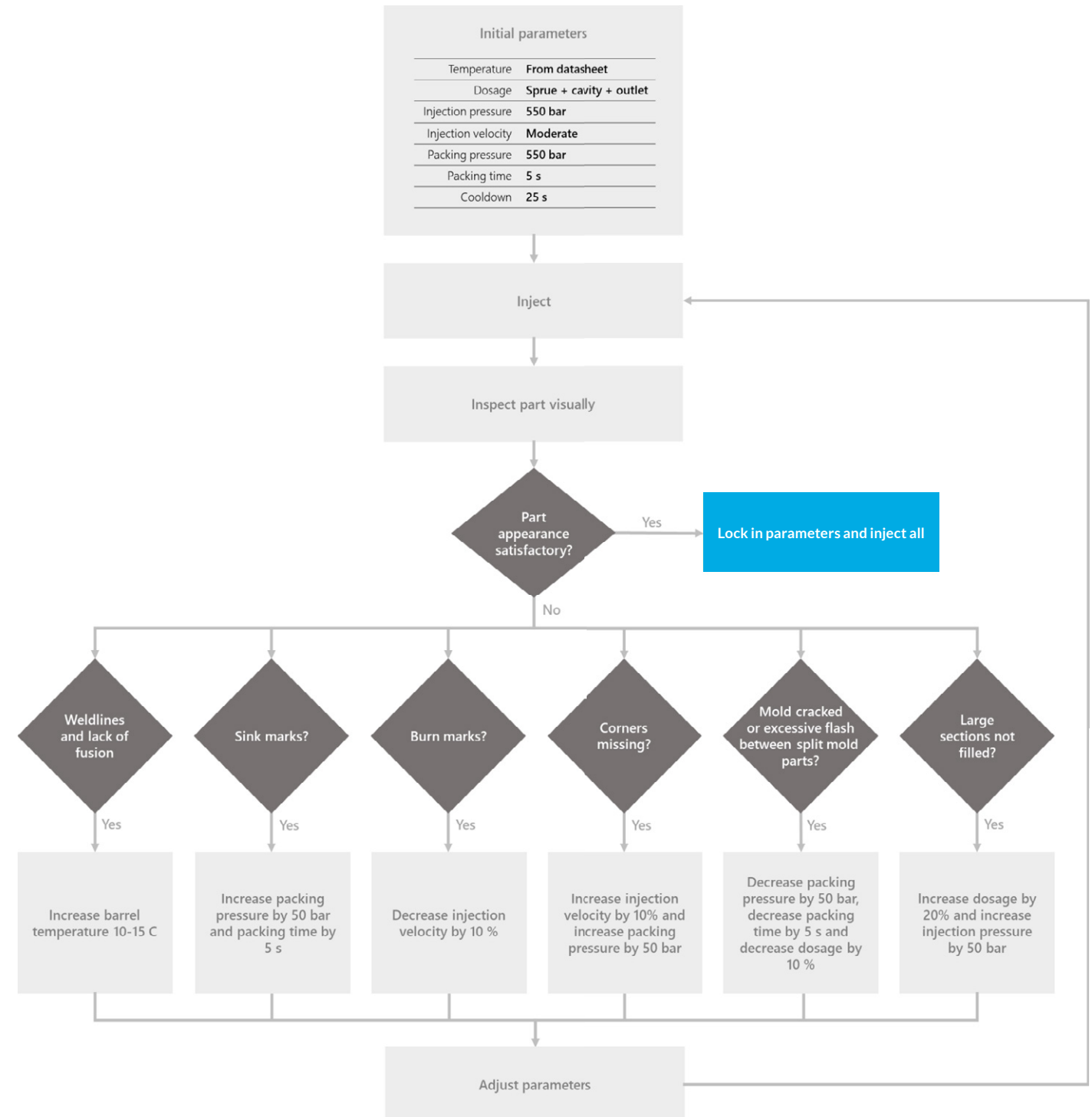
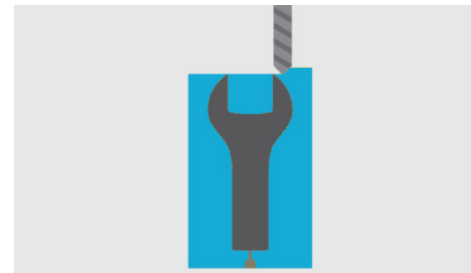

Accelerating Print

Demolding

The Nexa3D printing resins are dissolvable, thus designing for demolding is not necessary. In cases where fast results are desired, you may choose to use manual demolding, as demolding through dissolving takes 24–72 hours. The printed molds differ from metal molds, as their surface is not smooth, but lightly rippled from the layer fusing. Therefore, manual release of a component from printed molds can be harder.

Grooves around split lines

Add grooves in split lines to ease separation. The groove makes it easier to place a spatula or similar separation tool in between the two mold sections.

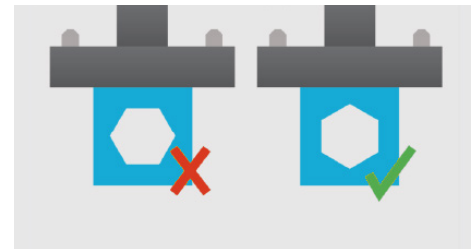

Limiting dissolving

In cases where aspects of the component design may only be freed from the mold through dissolving, or certain areas are too fragile for manual demolding, a mix method may be applied. Where the split mold is designed with appropriate cores and sections. So that sections of the mold can be manually removed. The less resin to dissolve, the quicker the dissolving.

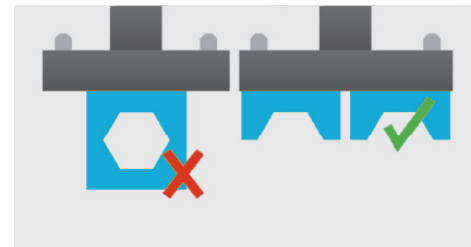

??

If the part cannot be rotated or split, it may also be a solution to print pillars of support material which can be removed manually.

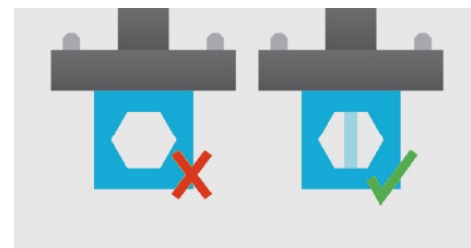

Testing your options

Splitting printed molds can present some challenges as the rippled surface can cause material to get in the mold and overall increases the components adherence to the mold. Therefore it is a good idea to print and fill 4–8 test molds when making a new part, to safely determine the optimal demolding approach with regards to time, tolerances and quality.

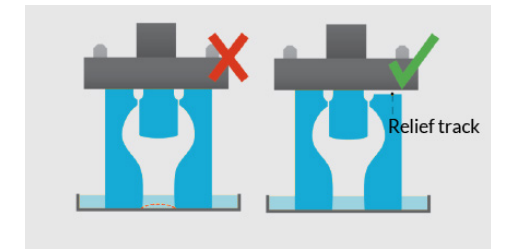

When to use slip

Using slip in printed resin molds can be helpful to release the component in some cases. However, some slip solutions may react with the resin or compromise the tolerances of the injected component.

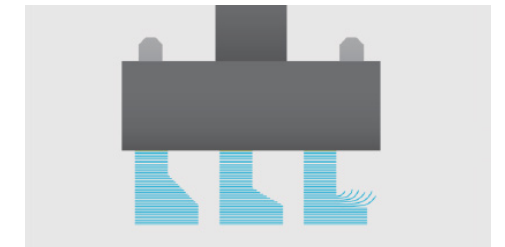

Chamfer towards build plane (not here)

Placing a chamfer on the surface connected to the build plane, makes it easier to remove printed molds from the build plane.

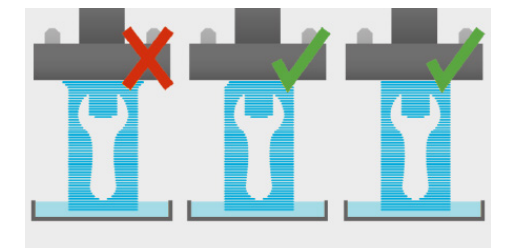

MIM & CIM Quick guide

FIM using powder materials (P-FIM)

FIM can also be used for powder materials – called PIM – like Metals and ceramics, called MIM and CIM respectively. When using such materials the process deviates from traditional FIM as the feedstock material consists of the powder material and a binder. This adds two steps to the process after demolding, called debinding and sintering. Where the former removes the binder and the latter shrinks and densifies the final part.

Mold design considerations

Shrinkage is unavoidable at the final step, thus the size factor must be applied either on the part dimensions or the FIM mold. As a rule of thumb, most MIM/CIM feedstocks have a size factor around 1.2 – 1.3, i.e. the mold is designed and printed to be 20–30% bigger than the desired final part.

MIM/CIM feedstocks are essentially a mixture of solid powder and binder which is responsible for the structural integrity of the molded part. The hard powder particles result in a significantly more viscous melt compared to polymer materials. Therefore, small features such as narrow channels or small gates/outlets should be avoided. Gate/outlet sizes that are used for polymers, will also apply here, but should not be smaller. It is advised to increase wall and wire thickness around small and narrow features as many of the MIM/CIM feedstocks require higher injection pressures and temperatures, compared to polymer materials.

Another important consideration is the use of retractable cores, meaning that part of the mold material is inserted in the mold during injection as a separate component to form the required cavity and shape. After the material cools down and the shape has formed, the retractable core is removed during the demolding step to avoid swelling in the center and stresses at areas of the part with low thickness, therefore low strength. Examples are cylindrical samples or areas with large hollow sections surrounded by thin walls. Alternatively designing traditional split molds could also be used with the FIM process.

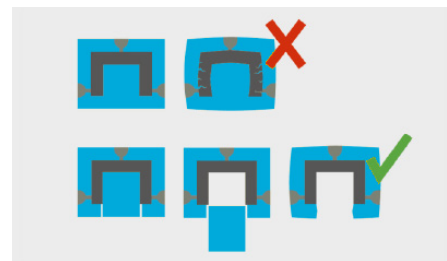
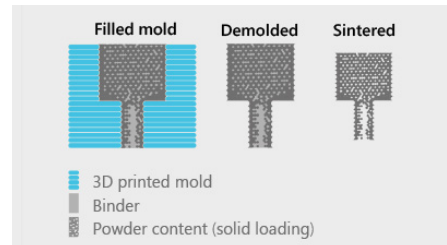
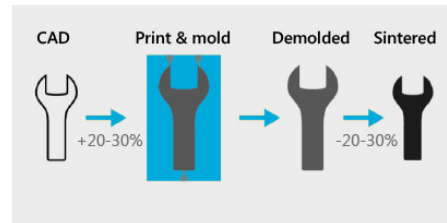
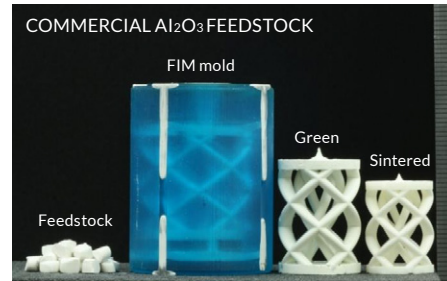

Injection parameters

The percentage of powder content (solid loading) in the feedstock impact the injection parameters, as do the component geometry and mold wall thickness. Higher powder content makes the feedstock harder to inject, often requiring higher injection pressures and temperatures. The feedstock viscosity is impacted by temperature and the shear forces applied by the injection screw. Increasing the injection pressure, speed and temperature may mitigate filling defects. Packing pressure and time are also important as the feedstock cools down. Be ware that excessive increases in injection pressure and temperature may distort features of the mold. In some cases uncontrolled expansion of the mold walls may even occur. The suggested parameters are a starting point, but specific injection parameters should be tested and determined on a case by case basis.

Material selection

The mixture of powder and binder in the feedstock material is important for the final properties. The binder material should exhibit the necessary chemical resistance to the demolding agent, since it's function is to hold the powder packed together and provide a degree of plasticity for the shaping process before it is removed at the debinding step. The selected powder should not interact and/or react with the demolding agent in order to achieve the desired functional requirements, compositions, and microstructures. The powder material will determine the sintering parameters. FIM is compatible with several commercial ceramic and metallic feedstocks, as well as experimental formulations with new, advanced powder material and high performance thermoplastic binders for targeted properties.

MIM/CIM parts are fragile in the green state, prior to sintering, thus demolding must be done with caution. This means handling the green samples with care when placing them and removing them from the demolding bath, as well as storing them properly so they will not collide or get compacted and break. The demolding solution causes the mold to slightly expand and this can lead to cracks in stress concentration points, especially if inner cores in the mold expand, as in the case of cylindrical features.

FIM is compatible with most commonly used high performance thermoplastic binders. For parts with complex geometries and inner mold cores, selecting a feedstock with a high strength binder such as POM is advised.

Suggested parameters:

- Injection pressure 700–2000 bar
- Injection temp 10°C above supplier's recommendation
- Packing pressure and time follow material parameters



Recommended binders include:

- Polyoxymethylene POM
- Ethylene Vinyl Acetate EVA
- Polyethylene PE
- Polyethylene Glycol PEG

MIM & CIM Quick guide

Debinding

Debinding refers to the removal of the organic polymer from the green part before sintering. Thermal debinding is the most common process used, where the binder undergoes thermal decomposition normally at a temperature range between 250°C and 600°C, depending on the formulation and the selected binder system. It is a lengthy, but simple process in terms of equipment and material handling. Solvent and catalytic debinding are other processes that can be used for more complex binder systems, reducing debinding time and controlling vapor release from the feedstock

After debinding samples are extremely brittle and should be carefully handled if necessary. Since the binders can release harmful gases during decomposition, the oven must be placed under a proper ventilation system.

The distribution of the binder in the feedstock formulation is critical for the final outcome. Areas with high concentration of binder will release vapors and this could result in cracking or void defects, making debinding an important step in the PIM process.

A dedicated heat treatment with slow heating rates 10–30°C/hr ensures a controllable release of gases and/or vapor and is advised for complex geometries. Proper placement and support of the samples should be considered as well.

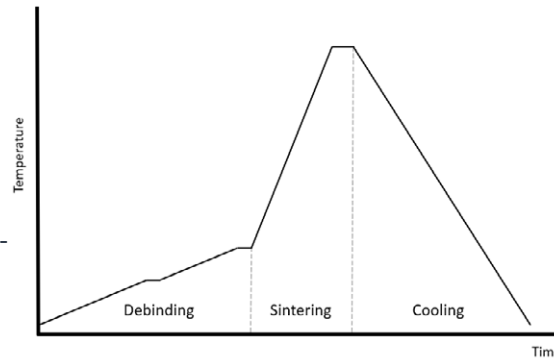

Sintering

Sintering will result in the final dense part, while different mechanisms such as solid state diffusion re-crystallisation and grain growth take place. A certain level of porosity is expected as a result of the sintering mechanism. Critical parameters in this case is the sintering temperature and time, that will vary depending on the powder material.

During sintering, higher heating rates can be applied above 60°C/hr and the final temperature is defined by the properties of the powder material. Post sintering, the part must undergo controlled cooling in the furnace. This is important to avoid uncontrollable phase transformation. In some cases a protective atmosphere may be required to avoid oxidation.

Debinding and sintering can be combined in a single heat treatment. However, contamination of the oven from the released vapors and diffusion of foreign elements could be an issue. Therefore, when working with different materials cross contamination must be considered.

As long as the demolding has not damaged the green parts, debinding and sintering are carried out as in a conventional PIM process.

Debinding and sintering equipment

Debinding sintering and cooling can all be done in the same furnace, at varying temperatures. In some cases the debinding may be done in a separate furnace. In instances where a protective atmosphere is required, a tube furnace must be used.

Chamber furnace

Simple and easy to operate for the majority of feedstock materials. Several options on chamber size and operating temperatures. A good and economical solution for small production volumes.

Sintering and cooling takes place in air, something that might limit the material choices. Using material specific furnaces will eliminate cross contamination and diffusion of unwanted elements.



Tube furnaces

A solution when sintering and cooling has to be carried out in a protective and/or reactive atmosphere. This will require the use of gas control and selection system that is connected as a module to the tube furnace installation.

The use of gases increases the complexity of the system. However, material specific tubes can be a great advantage when changing between materials, without the need to use a different oven.



nexa3D[®]

nexa3d.com